



USER MANUAL OF

PowerBase MATE LV

A05

OUR ENERGY WORKS FOR YOU

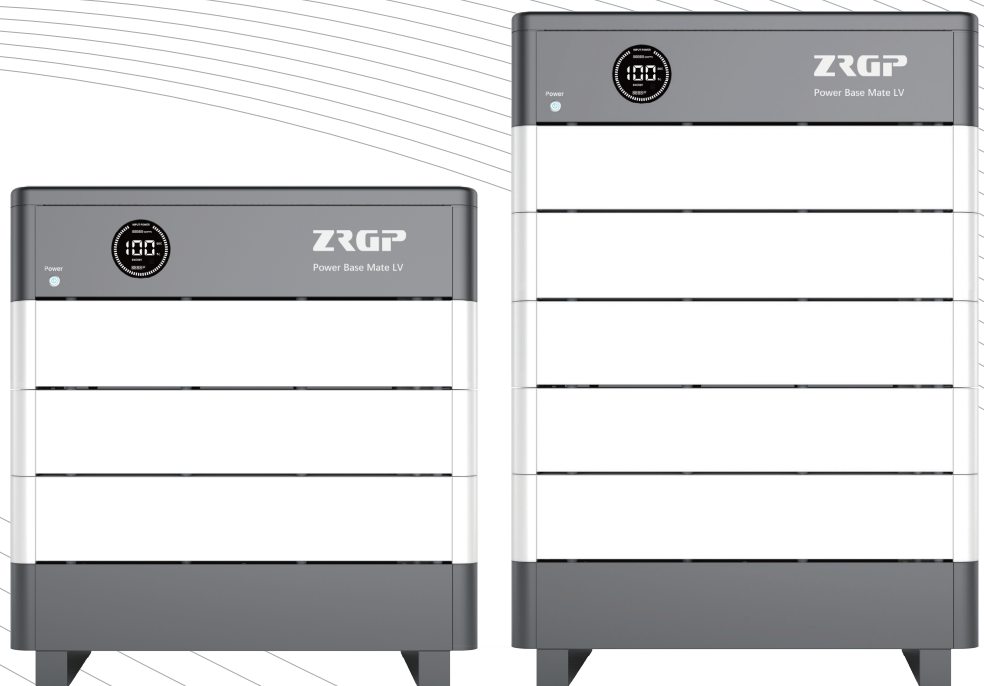

Zhongrui Green Energy Technology (Shenzhen) Co., Ltd.

All Rights Reserved. Specifications are subject to change without notice. 20250108.NO.1

Zhongrui Green Energy Technology (Shenzhen) Co., Ltd.

ZRGP is a national high-tech enterprise with a global vision. With independent research and development capabilities and focus on ESS solutions, ZRGP is becoming a world leading supplier of BMS, ESS, modules and monitoring systems. Our business scope integrates R&D, design, production and sales.

Headquartered in China, with multiple sales offices, product centers, factories, and wholly-owned subsidiaries around the world, ZRGP is committed to providing you with safe, lightweight and long-life green energy products.



ZRGP's industrial park boasts comprehensive facilities, including automated intelligent production lines, testing and aging sections, warehouse areas, office spaces, employee dormitories, cafeteria etc. A majority of the production and testing equipment possessed by the company is imported from Germany, whose advanced level and automation level are on the cutting edge of the industry.

21000m²

Factory Area

3GWh

Per Year

90+

Countries We Export To

Company Advantages

- Years of research and development experience
- Sales and after-sales outlets all over the world
- Highly information-based automated factory
- Scientific production process control ability



To produce world-class energy storage products
To serve the consumers in the global market

Table of Contents

1. Introduction	1
1.1. Lithium iron phosphate Battery	1
1.2. Mate LV Series	1
2. Safety Precautions	3
2.1. General warnings	3
2.2. Charge and discharge warnings	5
2.3. Transportation warnings	5
2.4. Disposal of lithium batteries	6
2.5. Emergency Situations	6
2.6. Before Connecting	7
3. Component' s Introduction and Daily Usage	8
3.1. Whole Cluster	8
3.2. Main Controller	10
3.3. Battery Module	16
3.4. Inverter	18
3.4.1. Supported brands	18
3.4.2. Inverter matching list	18
3.4.3. Inverter protocol dialing switch	19
3.4.4. Connection with inverter	21
3.4.5. Inverter CAN/RS485 communication port	23
3.5. Power on and power off the whole cluster	25
3.6. WiFi configuration and adding device	25
3.7. Automatic Matching Identification Function of Dial Switches 56 ~ 88:	30
4. Safe Handling of Lithium Batteries Guide	32
4.1. Schematic Diagram of Solution	32
4.2. Be Familiar with system	32
4.3. Precautions before Installation	33

4.4. Safety Gear	33
4.5. Tools	33
5. Installation	35
5.1. Package Items	35
5.2. Installation Location	38
5.3. Installation	38
5.4. Parallel connection(Optional)	45
6. Trouble Shooting Steps	47
6.1. Problem Determination Based on	47
6.2. Preliminary Determination Steps	47
6.3. The Battery Cannot be Charged or Discharged	48

1. Introduction

The purpose of this reference manual is to describe the Power Pack LV Series components, its functions, and the environment in which it can be operated properly. So that the user can understand the use scope and provide the necessary information for maintenance of the Power Pack LV Series when they need to.

1.1. Lithium iron phosphate Battery

The lithium iron phosphate battery is an energy storage product. It can be used to support reliable power for various types of equipment and systems. The product especially suitable for applications of high power, limited installation space, and restricted load-bearing and long cycle life. The lithium iron phosphate battery (LiFePO₄ or LFP) is the safest of the mainstream lithium battery types.

LFP is the chemistry of choice for very demanding applications. Some of its features are:

- ◆ Rugged - It can operate in deficit mode during long periods of time.
- ◆ For use in residential dwelling units and commercial buildings, indoor and outdoor.
- ◆ High round trip efficiency.
- ◆ High energy density - More capacity with less weight and volume.
- ◆ High charge and discharge currents - Fast charge and discharges are possible.
- ◆ Flexible charge voltages.
- ◆ The whole module is non-toxic, pollution-free, and environment-friendly.
- ◆ Cathode material is made from LiFePO₄ with safety performance and long cycle life.

1.2. Mate LV Series

Multiple battery stacks are allowed to be connected in parallel to expand capacity and power to meet the requirements of longer power supporting duration and higher power consumption. A single LFP cell has a nominal voltage of 3.2V.

Mate LV Series has a built-in BMS battery management system, which can manage and monitor cell's information including voltage, current and temperature.

- ◆ Battery management system (BMS) has protection functions including over-discharge, over-charge, and over-current and high/low temperature.
- ◆ The system can automatically manage charge and discharge state.
- ◆ Flexible configuration, multiple battery modules can be internal for expanding voltage and Capacity.
- ◆ Adopted self-cooling mode rapidly reduced system entire noise.
- ◆ The module has less self-discharge, up to 3 months without charging it on shelf, no memory effect, excellent performance of shallow charge and discharge.

- ◆ Working temperature range is from -20°C to 50°C, (Charging 0°C~50°C, discharging
- ◆ -20°C~50°C) with excellent discharge performance and cycle life.
- ◆ Small volume, light weight, plug-in embedded design module, easy to install and maintain.

2. Safety Precautions

It is very important and necessary to read the user manual carefully (in the accessories) before installing or using battery. Failure to do so or to follow any of the instructions or warnings in this document can result in electrical shock, serious injury, or death, or can damage battery, potentially rendering it inoperable.



Work on a Li-ion Battery should be carried out by qualified personnel only.



Observe these instructions and keep them located near the Li-ion Battery for future reference.



For more information about this product, please contact the installer.

2.1. General warnings



Any foreign object is prohibited to insert into any part of battery.



The warranty claims are excluded for direct or indirect damage due to items above.



Recharge and maintain the battery pack regularly every three months to ensure the battery is in the best condition.

Don't store the battery at 0% SOC for over one month, this may result in permanent damage to the battery and void the warranty.



It is prohibited to connect the battery with different type of battery.



It is prohibited to put the batteries working with faulty or incompatible inverter.



It is prohibited to disassemble the battery (QC tab removed or damaged).



Please do not open, repair, or disassemble the battery except trained technicians. We do not undertake any consequences or related responsibility which, because of violation of safety operation, or violation of design, production, and equipment



Do not expose battery to flammable or harsh chemicals or



Do not paint any part of battery; include any internal or external.



Do not drop, deform, impact, cut or spearing with a sharp



Do not wet the battery and avoid of direct



Do not use a damaged



Please contact the supplier within 24 hours if there is something



While working on the Li-ion Battery wear protective eyeglasses.



Any uncovered battery material such as electrolyte or powder on the skin or in the eyes must be flushed with plenty of clean water immediately. Then seek medical assistance. Spillages on clothing should be rinsed out with water.



Explosion and fire hazard. Terminals of the Li-ion Battery are always alive; Therefore, do not place items or tools on the Li-ion Battery, Avoid short circuits, too deep discharges, and too high charge currents. Use insulated tools. Do not wear any metallic items such as watches, bracelets, etc. In case of fire, you must use a type S, foam, or CO₂ fire extinguisher.



Do not open or dismantle the battery. Electrolyte is very corrosive. In normal working conditions contact with the electrolyte is impossible. If the battery casing is damaged do not touch the exposed electrolyte or powder because it is corrosive..



Li-ion batteries are heavy. If involved in an accident, they can become a projectile! Ensure adequate and secure mounting and always use suitable handling equipment for transportation.



Handle with care because an ion battery is sensitive to mechanical shock.



Do not expose cable outside, all the battery terminals must be disconnected.



Please use caution when it's placed around children or pets.



Do not use cleaning solvents to clean battery.

2.2. Charge and discharge warnings



If the battery is stored for a long time, it is required to charge them every three months, and the SOC should be no less than 90%.



Battery needs to be recharged within 12 hours, after fully discharged.



Do not connect battery with PV solar wiring directly.



Use only with BMS approved by the supplier.



If charged after the Lithium Battery was discharged below the “Discharge cut-off voltage”, or when the Lithium Battery is damaged or overcharged, the Lithium Battery can release a harmful mixture of gasses such as phosphate.



The temperature range over which the battery can be charged is 0°C to 50°C. Charging the battery at temperatures outside this range may cause severe damage to the battery or reduce battery life expectancy.



The temperature range over which the battery can be discharged is -20°C to 50°C. Discharging the battery at temperatures outside this range may cause severe damage to the battery or reduce battery life expectancy.

2.3. Transportation warnings



If the battery system needs to be moved or repaired, the power must be cut off and the battery is completely shut down; The battery must be transported in its original or equivalent package and in an upright position. If the battery is in its



Do not stand below a battery when it is



Never lift the battery at the terminals or the BMS communication cables, only lift the battery at the handles.



Battery packs need to be packed before they can be shipped, during transportation, severe impact, extrusion, direct sunlight and rain should be avoided.

Note:

- Batteries are tested according to UN Handbook of Tests and Criteria, part III, sub section 38.3 (ST/SG/AC.10/11/Rev.5).
- For transport the batteries belong to the category UN3480, Class 9, Packaging Group II and must be transported according to this regulation. This means that for land and sea transport (ADR, RID & IMDG) they must be packed according to packaging instruction P903 and for air transport (IATA) according to packaging instruction P965. The original packaging complies with these instructions.

2.4. Disposal of lithium batteries



Batteries marked with the recycling symbol must be processed via a recognized recycling agency. By agreement, they may be returned to the manufacturer.



Batteries must not be mixed with domestic or industrial waste.



Do not throw a battery into fire.

2.5. Emergency Situations

1) Leaking Batteries

If the battery pack leaks electrolyte, avoid contact with the leaking liquid or gas. If one is exposed to the leaked substance, immediately perform the actions described below.

Inhalation: Evacuate the contaminated area and seek medical attention.

Contact with eyes: Rinse eyes with flowing water for 15 minutes and seek medical attention.

Contact with skin: Wash the affected area thoroughly with soap and water and seek medical attention.

Ingestion: Induce vomiting and seek medical attention.

2) Fire

NO WATER! Only dry powder fire extinguisher can be used; if possible, move the battery pack to a safe area before it catches fire.

3) Wet Batteries

If the battery pack is wet or submerged in water, do not allow any person access, and then contact an authorized dealer for technical support.

4) Damaged Batteries

Damaged batteries are dangerous and must be handled with extreme care. They are not suitable for use and may cause danger to persons or property. If the battery pack appears to be damaged, place it in the original container and return it to an authorized dealer.

NOTE:

- *Damaged batteries may leak electrolyte or produce flammable gas.*
- *In case a damaged battery needs recycling, it shall follow the local recycling regulation to process, and using the best available techniques to achieve a relevant recycling efficiency.*

2.6. Before Connecting

- ◆ After unpacking, please check product and packing list first, if product is damaged or lack of parts, please contact with the local retailer.
- ◆ Before installation, be sure to cut off the grid power and make sure the battery is in the turned-off mode.
- ◆ Wiring must be correct, do not mistake the positive and negative cables, and ensure no short circuit with the external device.
- ◆ It is prohibited to connect the battery and AC power directly.
- ◆ The embedded BMS in the battery is designed for 48V DC, please DO NOT connect battery in series.
- ◆ Battery system must be well grounded, and the resistance must be less than 100mΩ.
- ◆ Make sure the grounding connection set correctly before operation.
- ◆ Please ensure the electrical parameters of battery system are compatible to related equipment.
- ◆ Keep the battery away from water and fire.

3. Component' s Introduction and Daily Usage

3.1. Whole Cluster

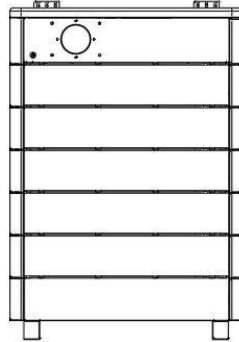

Figure 3.1. Overall system diagram of five battery modules

The form below is for Power Pack LV 15S.

No.	Items	Parameters							
1	Model	ZR-PBML-**SE							
2	Controller Module	ZR-MC100-200M2							
3	Battery Module Type	ZR-FS48100-15OSJ1							
4	Battery Module Chemistry	LiFePO4							
5	Battery Module QTY	2	3	4	5	6	7	8	
6	Nominal Capacity (Ah)	200	300	400	500	600	700	800	
7	Nominal Energy(kWh)	9.60	14.4	19.2	24.0	28.8	33.6	38.4	
8	Voltage	Nominal(V)	48.0						
		Recommend Charging(V)	53.25						
		Max. Charging(V)	55.5						
		Discharge Cut-off(V)	40.5						
9	Current	Max. Charging(A)	180	270	300	300	300	300	300
		Max. Discharging(A)	180	270	300	300	300	300	300
		Peak for 10s(A)	300	300	500	500	500	500	500
10	Weight (Approx.)	304lbs	416lbs	527lbs	639lbs	750lbs	862lbs	972lbs	
11	Dimensions(L*H*W)	735*1040 *400mm@24.0 kwh (Each module has a height of 135.5mm)							
12	Communication	RS485, CAN, Wi-Fi, RS232							
13	Cycle Life	6000 times@80%DOD							
14	Designed Calendar Life	≥10 years							

15	Safety Function	Over-charge, Over-discharge, Over-current, Low/High-temperature, Low-voltage, Short-circuit Protections
16	Parallel Capability	Maximum 15 Cluster (Recommended 6 Cluster)

The form below is for Power Pack LV 16S.

No.	Items	Parameters							
1	Model	ZR-PBML-**S							
2	Controller Module	ZR-MC100-200M2							
3	Battery Module Type	ZR-FS48100-16OSJ1							
4	Battery Module Chemistry	LiFePO4							
5	Battery Module QTY	2	3	4	5	6	7	8	
6	Nominal Capacity (Ah)	200	300	400	500	600	700	800	
7	Nominal Energy(kWh)	10.24	15.36	20.48	25.6	30.72	35.84	40.96	
8	Voltage	Nominal(V)	51.2						
		Recommend Charging(V)	56.8						
		Max. Charging(V)	59.2						
		Discharge Cut-off(V)	43.2						
9	Current	Max. Charging(A)	180	270	300	300	300	300	300
		Max. Discharging(A)	180	270	300	300	300	300	300
		Peak for 10s(A)	300	300	500	500	500	500	500
10	Weight (Approx.)	311lbs	425lbs	540lbs	655lbs	769lbs	884lbs	999lbs	
11	Dimensions(L*H*W)	735*1040 *400mm@24.0 kwh (Each module height 135.5mm)							
12	Communication	RS485, CAN, Wi-Fi, RS232							
13	Cycle Life	6000 times@80%DOD							
14	Designed Calendar Life	≥ 10 years							
15	Safety Function	Over-charge, Over-discharge, Over-current, Low/High-temperature, Low-voltage, Short-circuit Protections							
16	Parallel Capability	Maximum 15 Cluster (Recommended 6 Cluster)							

3.2. Main Controller

1. Component introduction

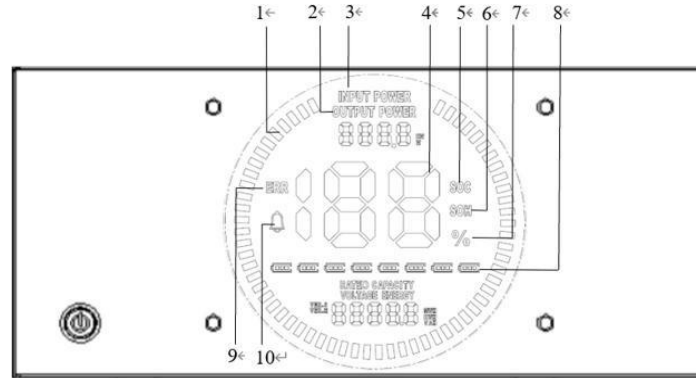

Figure 3.2.1 Controller module positive

No.	Instructions	NO.	Instructions
1	Animated streamline	6	Battery state of health (SOH)
2	Discharge power	7	Numerical percentage
3	Charging power	8	Number of modules
4	Numerical information	9	Fault (error)
5	Battery state of charge (SOC)	10	Alarm (warning)

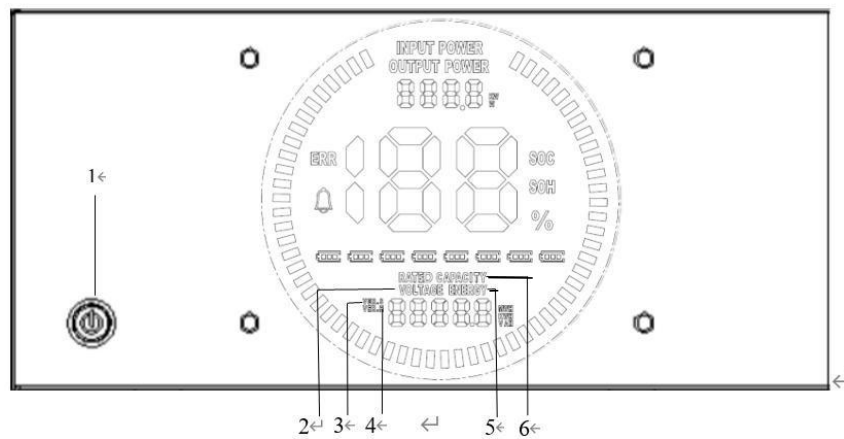

Figure 3.2.2 Controller module positive

No.	Instructions	NO.	Instructions
1	Power switch	4	Hardware version
2	Current voltage level	5	Energy throughput
3	Software version	6	Capacity of a new battery

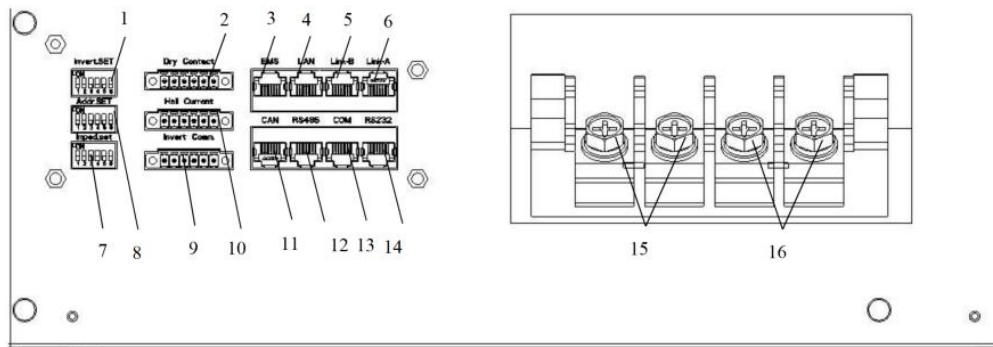

Figure 3.2.3 Interface definition of Controller module

No.	Component	Function
1	Inverter protocol dialing switch	Set address to communicate with inverter
2	Dry Contact (Reserved)	Reserved port
3	Reserved	Reserved port
4	Reserved	Reserved port
5	Parallel communication port B	Port to parallel another cluster
6.	Parallel communication port A	Port to parallel another cluster
7.	Imped.SET	Set resistance to match circuit
8	Address Dial Switch of Cluster	Set address of cluster for paralleling
9	Inverter CAN /RS485communication port	The communication port which can fit with both of CAN and RS485 protocol for inverter
10	Hall Current (Reserved)	Reserved port
11	Inverter CAN communication port	The communication port which can fit with CAN for inverter

12	Inverter RS485communication port	The communication port which can fit with RS485 protocol for inverter
13	CAN upgrade communication port	The port for upgrade in CAN protocol
14	RS232 communication interface	The port for communication in RS232 protocol
15	Charge discharge negative electrode	Negative electrode of cluster
16	Charge discharge positive electrode	Positive electrode of cluster

Power switch

Power switch: turn on/off the input and output of the whole system.

Display screen

Display screen: the interface can observe the operation status information SOC, SOH, charging and discharging power, alarm fault indication, charging and discharging status display and system status indication of the whole system.

Address dial switch

Dial switch: 6-digit dial switch, address "0" and "1", as shown in the figure. After setting, you need to restart the system and activate it.

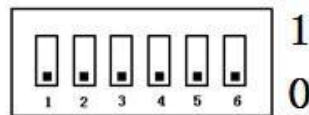

When the system groups are in parallel, the communication between two levels is needed. Both master and slave packets need hardware address configuration, and the hardware address can be set through the dial switch on the board. The definition of switch is shown in the table below.

Address Coding	Dial Code Switch Position						Definition
	#1	#2	#3	#4	#5	#6	
1	ON	OFF	OFF	OFF	OFF	OFF	The host computer can monitor the operation of other systems by setting the main package
2	OFF	ON	OFF	OFF	OFF	OFF	Set to the slave Cluster 2
3	ON	ON	OFF	OFF	OFF	OFF	Set to the slave Cluster 3
4	OFF	OFF	ON	OFF	OFF	OFF	Set to the slave Cluster 4

5	ON	OFF	ON	OFF	OFF	OFF	Set to the slave Cluster 5
6	OFF	ON	ON	OFF	OFF	OFF	Set to the slave Cluster 6
7	ON	ON	ON	OFF	OFF	OFF	Set to the slave Cluster 7
8	OFF	OFF	OFF	ON	OFF	OFF	Set to the slave Cluster 8
9	ON	OFF	OFF	ON	OFF	OFF	Set to the slave Cluster 9
10	OFF	ON	OFF	ON	OFF	OFF	Set to the slave Cluster 10
11	ON	ON	OFF	ON	OFF	OFF	Set to the slave Cluster 11
12	OFF	OFF	ON	ON	OFF	OFF	Set to the slave Cluster 12
13	ON	OFF	ON	ON	OFF	OFF	Set to the slave Cluster 13
14	OFF	ON	ON	ON	OFF	OFF	Set to the slave Cluster 14
15	ON	ON	ON	ON	OFF	OFF	Set to the slave Cluster 15

2. Status code

Status code: When the system status code is displayed as protection information, only the value will be displayed. When the system status code is displayed as fault information, error and warning code will be displayed. The definition of alarm is shown in the table below:

Warning Code (Sigh like “🔔”)	
1	Single Overvoltage Protection
2	Single low voltage protection
3	Charge overcurrent protection
4	Discharge overcurrent protection
6	Battery charging high temperature protection
7	Cell discharge high temperature protection
8	Battery charging low temperature protection
9	Cell discharge low temperature protection
11	High ambient temperature protection
12	Overpressure protection

21	Parallel failure protection
22	Relay over temperature protection
23	Copper busbar over temperature protection
24	Low insulation protection
51	Total voltage overcharge protection
52	Total voltage over-discharge protection
53	Low ambient temperature protection
54	MOS over temperature protection
55	MOS low temperature protection

Warning Code (Sigh like "ERR")	
5	Short circuit protection
13	Discharge circuit failure
14	Charge circuit failure
15	Cell failure
16	NTC out-of-school failure
17	Voltage acquisition out-of-calibration fault
18	Hall sensor failure
19	External device communication interruption fault
20	Internal device communication interruption failure
25	The communication between the screen and the device was lost
26	Microelectronics failure

NOTE:

- *When the system is charged, the display streamline gathers in the middle, and when it is discharged, the display streamline disperses to both sides.*

3. Impred.SET

Switch: 6 switches, "0" and "1", refer to picture right. The settings will be active only after restart the battery.

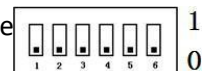

After assembling the product, dial the sixth bit of this dip code by 1, which is in the form of 000001, the purpose is to maintain the communication stability of the device.

4. Link-A/Link-B communication port

Link-A/Link-B communication port: (RJ45 port) the definition of link A and B are same. RS485 interface is used for parallel communication between the Controller modules, and up to 15 devices can be connected in parallel.

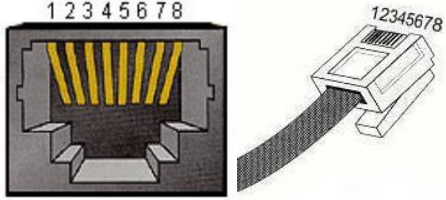
Port definitions	RJ45 Pin	Function
	1	RS485-B
	2	RS485-A
	3	RS485-GND
	4	NC (NO connect)
	5	NC (NO connect)
	6	RS485-GND
	7	RS485-A
	8	RS485-B

5. RS232 Communication port

RS232 communication port: (RJ45 port) comply comply with RS232 protocol (baud rate: 9600), for manufacturers or professional engineers debugging or service.

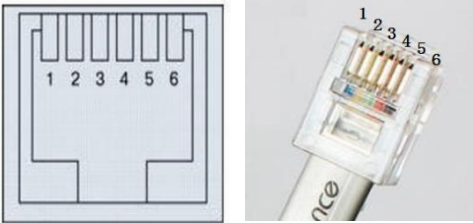
Port definitions	RJ45 Pin	Function
	1	NC (NO connect)
	2	RS232-GND
	3	RS232-TX
	4	RS232-RX
	5	RS232-GND
	6	NC (NO connect)

6. COM communication port

COM communication port: (RJ45 port) Connect the monitoring host computer to query the data and monitor the running status of the system.

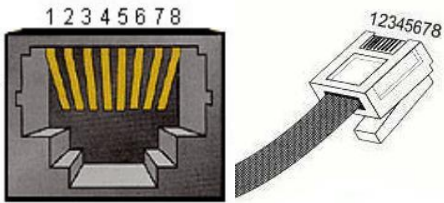
Port definitions	RJ45 Pin	Function
	1	RS485-B
	2	RS485-A
	3	CAN -GND
	4	RS485-GND
	5	RS485-GND
	6	CAN -GND
	7	CAN-L
	8	CAN-H

3.3. Battery Module

Components of Battery Modules

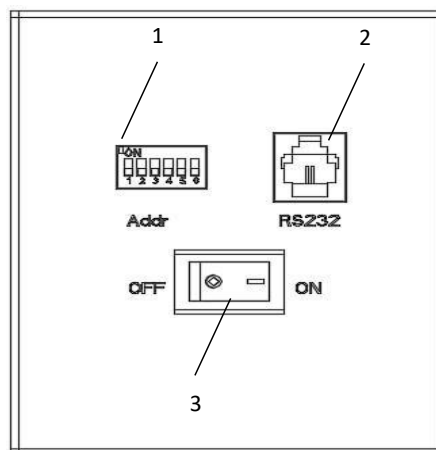

Figure 3.3. Battery module interface definition

No.	Instructions	NO.	Instructions
1	Address Dial Switch of Battery Module	3	Power switch
2	RS232 communication interface		

Power switch

Power switch: turn on/off the input and output of the whole battery module.

RS232 communication port

RS232 communication port:(RJ11 port) comply with RS232 protocol (baud rate: 9600), for manufacturers or professional engineers debugging or service.

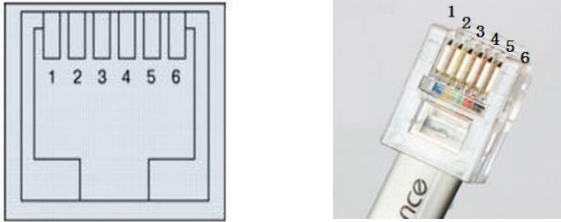
Port definitions	RJ11 Pin	Function
	1	NC (NO connect)
	2	RS232-GND
	3	RS232-TX
	4	RS232-RX
	5	RS232-GND
	6	NC (NO connect)

Address dial code

ADD switch: 6 ADD switches, "0" and "1", refer to graph below. The settings will be active only after restart the battery.

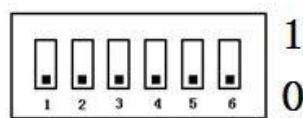

When the battery communicates with the inverter, the address of the battery pack must be set to 1, and the address of the parallel slave should be greater than 1.

The master control is the host, and the FS battery is the slave. The host broadcasts the voltage of the parallel bus. After the slave is powered on, check whether there is voltage at the port.

Otherwise, turn off the discharge MOSFET and turn on the Controller.

1. Refresh the dialing address when waking up from sleep, otherwise the address before shutdown will be used for startup judgment.
2. 0 does not participate in parallel operation or single machine operation (MOS does not close under any state); The hardware address can be set through the dial switch on the board. The definition of switch is shown in the following table.

AddressCoding	Dial Code Switch Position						Definition
	#1	#2	#3	#4	#5	#6	
1	ON	OFF	OFF	OFF	OFF	OFF	Set to the slave Pack1
2	OFF	ON	OFF	OFF	OFF	OFF	Set to the slave Pack2
3	ON	ON	OFF	OFF	OFF	OFF	Set to the slave Pack 3
4	OFF	OFF	ON	OFF	OFF	OFF	Set to the slave Pack 4
5	ON	OFF	ON	OFF	OFF	OFF	Set to the slave Pack 5
6	OFF	ON	ON	OFF	OFF	OFF	Set to the slave Pack 6
7	ON	ON	ON	OFF	OFF	OFF	Set to the slave Pack 7
8	OFF	OFF	OFF	ON	OFF	OFF	Set to the slave Pack 8

Battery anode and Battery cathode

Positive and negative connection: the battery modules are connected in parallel through the connecting terminals, and finally the Controller module is connected in parallel. The power cable adopts waterproof connector. When connecting the power plug, its corresponding interface must be aligned.

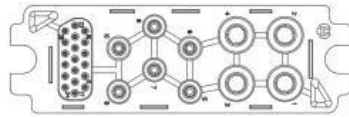

The waterproof box

To open the water-proof box of battery module, users need to loosen the screws on both sides firstly, and then users need to press down the pick which is in the middle lower part of the waterproof box. The outer cover can be opened in that way.

3.4. Inverter

3.4.1. Supported brands

At present, the energy storage products of our company have completed matching tests with some series inverters of the following brands, and we will continue matching tests with inverters of other companies. Please check our official website for the latest list of supporting brands.

POWER BASE LV-MATE Compatible Inverter List



POWER BASE HV-MATE Compatible Inverter List



3.4.2. Inverter matching list

The list tab only lists the inverter manufacturers one of the same series products, general inverter manufacturers in the same series of other products, the communication protocol are the same, so our battery can be communicated with the other products of same series inverter, if encounter a series of products can't communication, please contact us.

The following inverter matching list may not be up to date. The list may change according to the software version upgrade, and the reference manual may does not change immediately according to the software version upgrade. Therefore, if the user wants to get the latest

inverter matching support, please browse our official website to check the relevant documents.

The inverter manufacturer may upgrade its software version, which may cause problems in the communication between our battery and the inverter. Therefore, before communicating with the inverter, please confirm whether the software version of the inverter is consistent with the list. If not, please contact us.

Inverter			Communicationmode
Brand	Type	Protocol Version	
DEYE	SUNSYNK-5K-SG01LP1	V1.5	CAN
Growatt	SPF 12KT HVM	V1.22	RS485
	SPH3000	V1.26	CAN
GreenCell	PV1800 VHM	V1.04.04	CAN
Li_PLUS	ZRStandard	V1.2	CAN
Must	PV1800 VHM	V1.04.04	CAN
Sol-ark	Sol-ark-12k	V1.31	CAN
Studer	Xtender-XTH-8000-48	V1.0.3	Xcom-CAN
Sofar	HYD5000-ES	V6.0	CAN
Solis	RHI-5K-48ES	V1.2	CAN
SMA	S16.0H-12	V2.0	CAN
Sermatec	SMT-5K-TL-UN	V1.2	CAN
Schneider	Conext TM Gateway	V2.0	CAN
Victron	MultiPlus-II	V6.0	CAN

3.4.3. Inverter protocol dialing switch

ADD switch: 6 ADD switches, “0” and “1”, refer to picture below.

When the host is connected to the inverter, the host computer needs to communicate. Hardware address configuration is required on the host, and the hardware address can be set through the dial switch on the board.

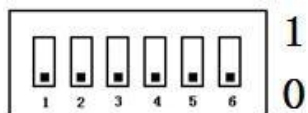

1. Inverter protocol setting function of dial switch 0 ~ 31: The inverter communication protocol can be changed directly by setting the dial switch, the definitions are shown in the following table.

Address Coding	Dial Code Switch Position						Definition
	#1	#2	#3	#4	#5	#6	
0	OFF	OFF	OFF	OFF	OFF	OFF	Monitoring Software settingmode
1	ON	OFF	OFF	OFF	OFF	OFF	ZRGP
2	OFF	ON	OFF	OFF	OFF	OFF	Studer_Xtender
3	ON	ON	OFF	OFF	OFF	OFF	Sofar_LV
4	OFF	OFF	ON	OFF	OFF	OFF	Solis_LV
6	OFF	ON	ON	OFF	OFF	OFF	Victron_color control
7	ON	ON	ON	OFF	OFF	OFF	SMA_LV
8	OFF	OFF	OFF	ON	OFF	OFF	Sermatec_LV
9	ON	OFF	OFF	ON	OFF	OFF	Reserved
10	OFF	ON	OFF	ON	OFF	OFF	Growatt_SPF
11	ON	ON	OFF	ON	OFF	OFF	Li_PLUS
12	OFF	OFF	ON	ON	OFF	OFF	Schneider_Gateway
13	ON	OFF	ON	ON	OFF	OFF	SOL-ARK_LV
14	OFF	ON	ON	ON	OFF	OFF	Phocos-AnyGrid
15	ON	ON	ON	ON	OFF	OFF	AFORE-LV
16	OFF	OFF	OFF	OFF	ON	OFF	Voltronic Power
17	ON	OFF	OFF	OFF	ON	OFF	DEYE
18	OFF	ON	OFF	OFF	ON	OFF	Growatt_SPH
19	ON	ON	OFF	OFF	ON	OFF	Reserved
20	OFF	OFF	ON	OFF	ON	OFF	Reserved

21	ON	OFF	ON	OFF	ON	OFF	SAJ-LV
22	OFF	ON	ON	OFF	ON	OFF	SMA-LV
23	ON	ON	ON	OFF	ON	OFF	Reserved
24	OFF	OFF	OFF	ON	ON	OFF	Fronius
25	ON	OFF	OFF	ON	ON	OFF	Lux
26	OFF	ON	OFF	ON	ON	OFF	Reserved
27	ON	ON	OFF	ON	ON	OFF	GreenCell
28	OFF	OFF	ON	ON	ON	OFF	Reserved
29	ON	OFF	ON	ON	ON	OFF	Must
30	OFF	ON	ON	ON	ON	OFF	MEGAREVO-LV
31	ON	ON	ON	ON	ON	OFF	Aiswei-LV

3.4.4. Connection with inverter

This section will introduce how to connect the different brands inverter with our products. Inverters manufacturers may upgrade their products, resulting in hardware communication interface changes. If communication is not possible in the application according to the following wiring method, please contact with us.

The CAN/RS485 communication port of CENTRAC relates to the communication interface of inverter.

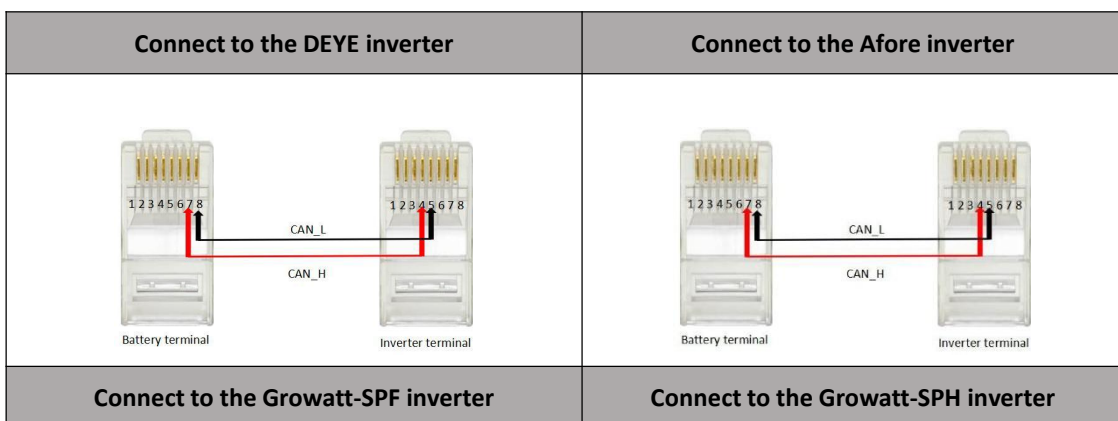

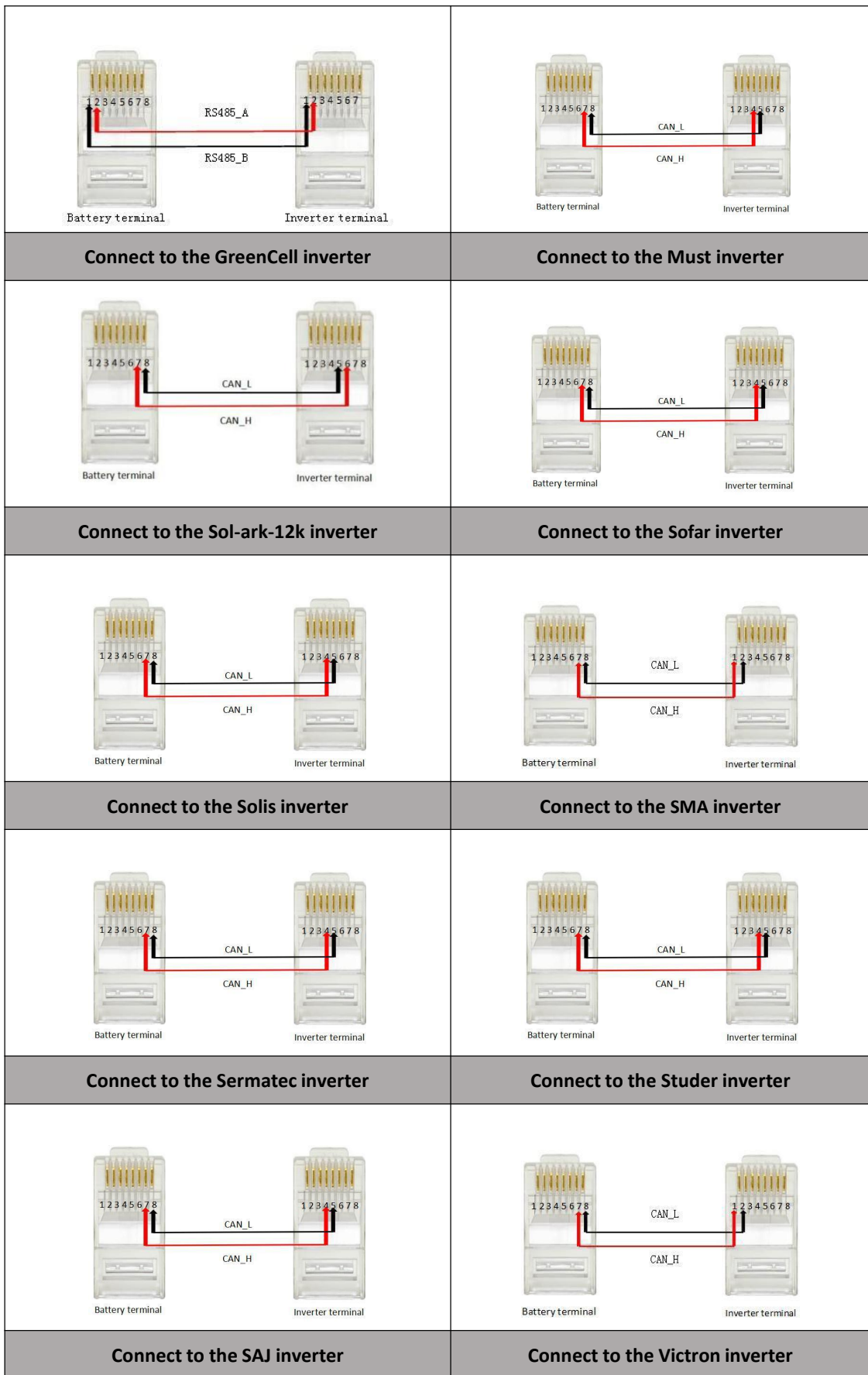

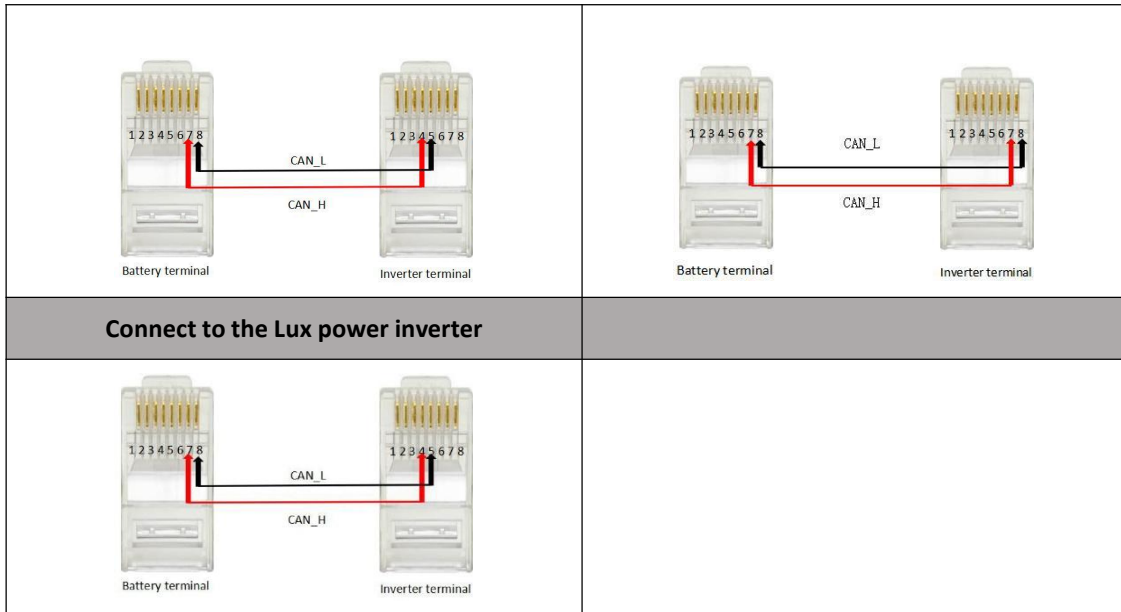

- If you are using the pin order select box, please refer to the table above to set the dial switch, according to the inverter brand.
- For example, if you want to match a Deye inverter, you should dial 4 high and 5 low on the CAN side as shown in the following figure.

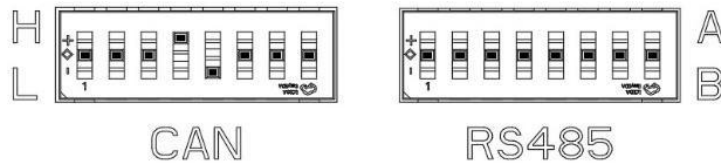

- If the inverter brand is not shown in the table, please refer to the inverter manual or consult BlauHoff's engineer.

NOTE:

- The above CAN and RS485 communication connections are not connected the ground wire, in the application of relatively large interference, it is recommended to connect the ground wire, the ground wire connection method is a single-ended shielding line.
- If you want to view inverter matching and dip details, please visit our website <https://zruipower.com/wp-content/uploads/2023/09/Inverter-Matching-Guide-ZRGP-battery1.pdf>.

3.4.5. Inverter CAN/RS485 communication port

Inverter CAN/RS485 communication port: (3.81mm port) follows can protocol and RS485 protocol. For the output system information, the system master uses this interface to communicate with External inverter PC and other equipment.

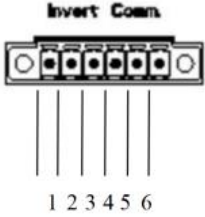
Port definitions	6Pin	Function
	1	RS485-B
	2	RS485-A
	3	RS485 -GND
	4	CAN-L
	5	CAN-H
	6	CAN -GND

Inverter RS485 communication port

The rear panel RS485 communication port: (RJ45 port) follows can protocol and RS485 protocol. For the output system information, the system master uses this interface to communicate with External inverter PC and other equipment.

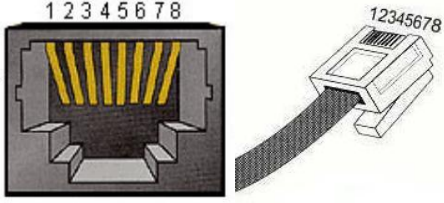
Port definitions	RJ45 Pin	Function
	1	RS485-B
	2	RS485-A
	3	RS485-GND
	4	NC (NO connect)
	5	NC (NO connect)
	6	RS485-GND
	7	RS485-A
	8	RS485-B

Inverter CAN communication port

Rear panel CAN communication port: (RJ45 port) follows can protocol and RS485 protocol. For the output system information, the system master uses this interface to communicate with the external inverter PC and other equipment.

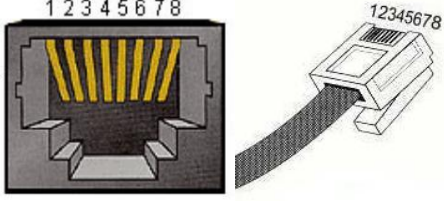
Port definitions	RJ45 Pin	Function
	1	CAN-H
	2	CAN-L
	3	CAN -GND
	4	NC (NO connect)
	5	NC (NO connect)
	6	CAN -GND
	7	CAN-H
	8	CAN-L

3.5. Power on and power off the whole cluster

To power on the whole cluster, user needs to set address dial switch of controller and battery module at first. Users need to up-toggle the rightmost resistance switch which is “6” in.

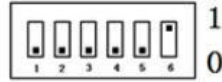

Imped.SET as well.

And then user need to toggle switch of the battery module and press on power button of the main controller.

In the third step, user needs to observe the screen of the controller. If there is no reappearing pear on the screen and the number of modules is correct, the battery can operate normally. If there are any errors, please detect the battery again according to status code which user can find in 3.2 section.

To power off the cluster, user need to press on the power button again. Make sure the light extinguished after pressed the button.

3.6. WiFi configuration and adding device

1. Screw the antenna into the antenna connection port firmly before Wi-Fi configuration.
2. Set the inverter dip switch of the battery to 56 to enable battery Wi-Fi.

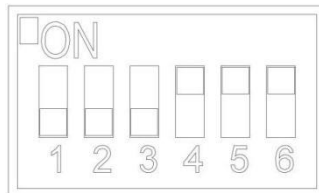

3. Download and install ZRGP APP from Google or Apple Store by searching Z-Cloud.



4. You may acquire the Register Code from your installer for new account registration. If you already had an account, you may use it to log in the APP directly otherwise you need to create an account.



5. Turn to the page 'Toolbox' then click the Network, following by the instruction of network setting for Wi-Fi configuration.

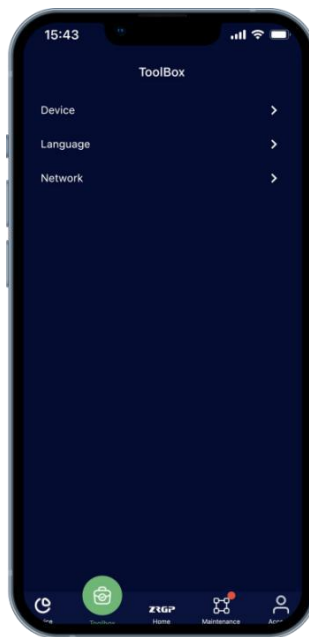

6. Connect your mobile phone to the Wi-Fi hotspot from the master controller which SSID is same as controller's serial number (SN) and the password is 12345678.

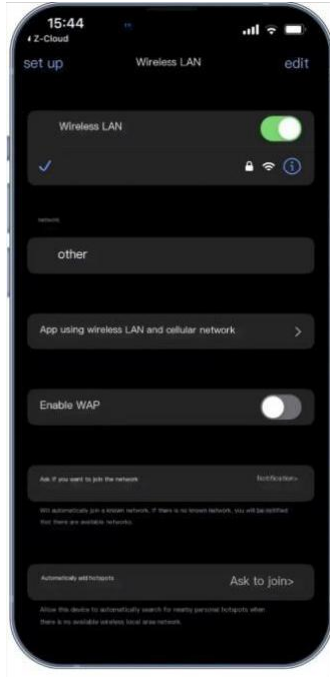

7. Enter the SSID and password of your private Wi-Fi for connecting master controller to your private Wi-Fi.



8. Set the inverter dip switch to matching inverter serial number. Please find the detailed comparison table on page 21.

9. Ask your installer to assign all your products to your account.

10. Turn to main page of the APP, create a plant, and set a recognizable name, your email and address for it.

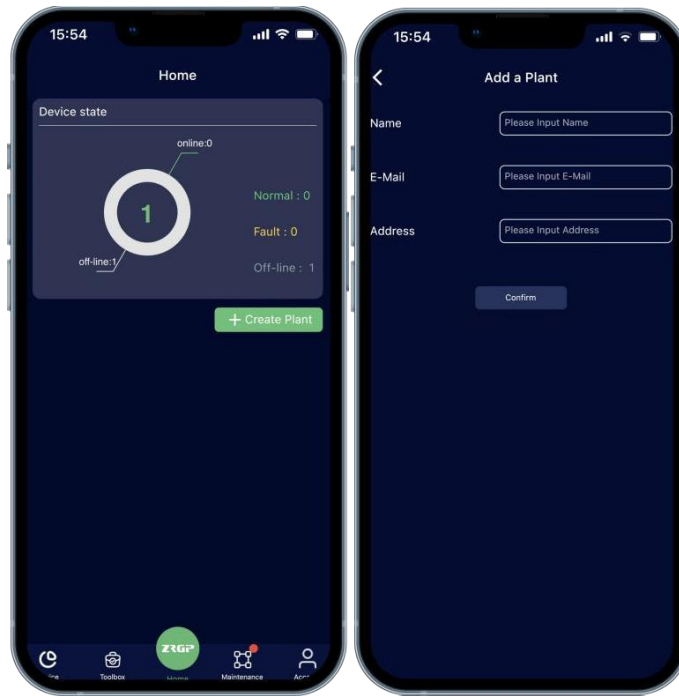

11. Click the confirm button to create your plant and all your products will show up as their SN, select proper products and confirm.

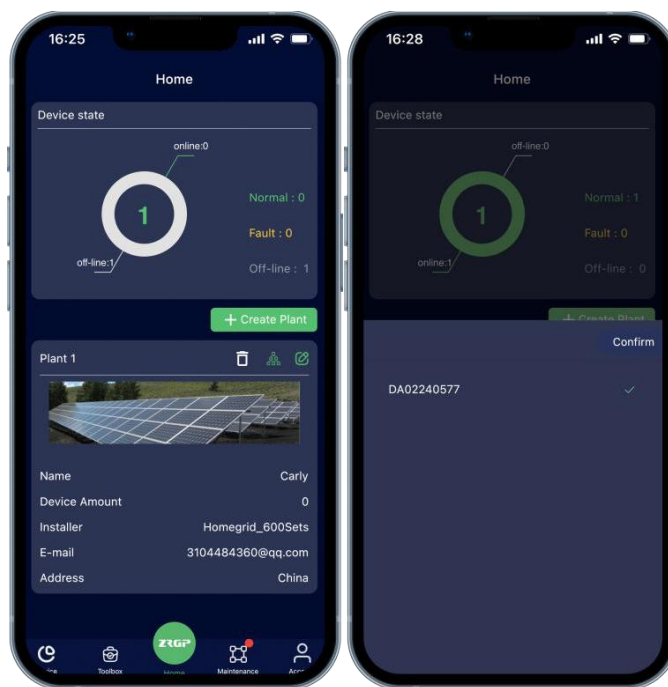

12. Now you can manage your products in the APP, and you can also manage them in Website, ask your installer for the site URL.

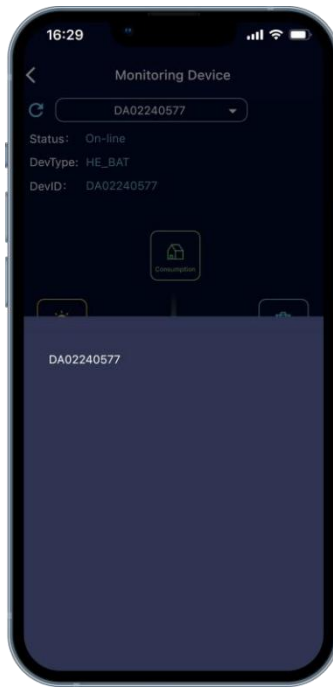





13. After the product is connected to Wi-Fi, the running status, real-time power, daily power consumption and cumulative power of the product can be monitored in real-time on the network platform or mobile APP. It can also be used to configure parameters.



3.7. Automatic Matching Identification Function of Dial Switches 56 ~

88:

Special functions of the inverter dip switch: Different dip switches have special functions.

Code	Dial Switch	Mode	Explanation	Remarks
56		Wi-Fi Config Mode	The hotspot of the device will be turned on under this mode and will be off after exiting this mode. 0 means the hotspot is being turned on 1 means the hotspot is on and you can find it on your phone 2 means the Z-Cloud APP has connected to the device 3 means the Wi-Fi name and password has been received from the APP	1) It may take up to 1 min from 0 to 1 2) It will go back to 0 if no phone is connecting to the hotspot for too long, you need to exit and enter this mode again 3) When you push Wi-Fi info from the APP, the screen will show 3 for 1 second and then jump to 0 quickly, this is normal.
60		Wi-Fi Status mode	Check the WIFI status: 0 means the device is not connected to any Wi-Fi router 1 means the device is connected to the Wi-Fi router 2 means the device is connected to the server	1) It may take up to 1 min from 0 to 1 2) It may take up to 5 min from 1 to 2
61		Info Mode	The Screen will show the hardware and software version of the EMS, BMS and Modules 101 means EMS 102 means BMS 1~8 means module 1~8	1) only works on Gen3 BMS
62		BMS Detection mode	Let the master BMS detect how many BMS is installed	1) detection may take up to 1 min 2) please wait for at least 25 seconds before changing back to normal mode, otherwise it won't be affected.
63		Module Detection mode	Let the BMS detect how many modules is installed	1) detection may take up to 1 min 2) please wait for at least 25 seconds before changing back to normal mode, otherwise it won't be affected.
70	No need to set	Download Mode	Downloading the firmware for EMS, the process will be indicated from 1 to 100	It may take up to 15 min for the downloading, depending on the internet condition.
71			Downloading the firmware for BMS, the process will be indicated from 1 to 100	
72			Downloading the firmware for Module, the	

			process will be indicated from 1 to 100	
80	No need to set	Update Mode	The BMS is being updated, the process will be indicated from 1 to 100	It may take up to 1 min
81			Module 1 is being updated, the process will be indicated from 1 to 100	It may take up to 4 min for each module
82			Module 2 is being updated, the process will be indicated from 1 to 100	
83			Module 3 is being updated, the process will be indicated from 1 to 100	
84			Module 4 is being updated, the process will be indicated from 1 to 100	
85			Module 5 is being updated, the process will be indicated from 1 to 100	
86			Module 6 is being updated, the process will be indicated from 1 to 100	
87			Module 7 is being updated, the process will be indicated from 1 to 100	
88			Module 8 is being updated, the process will be indicated from 1 to 100	

4. Safe Handling of Lithium Batteries Guide

4.1. Schematic Diagram of Solution

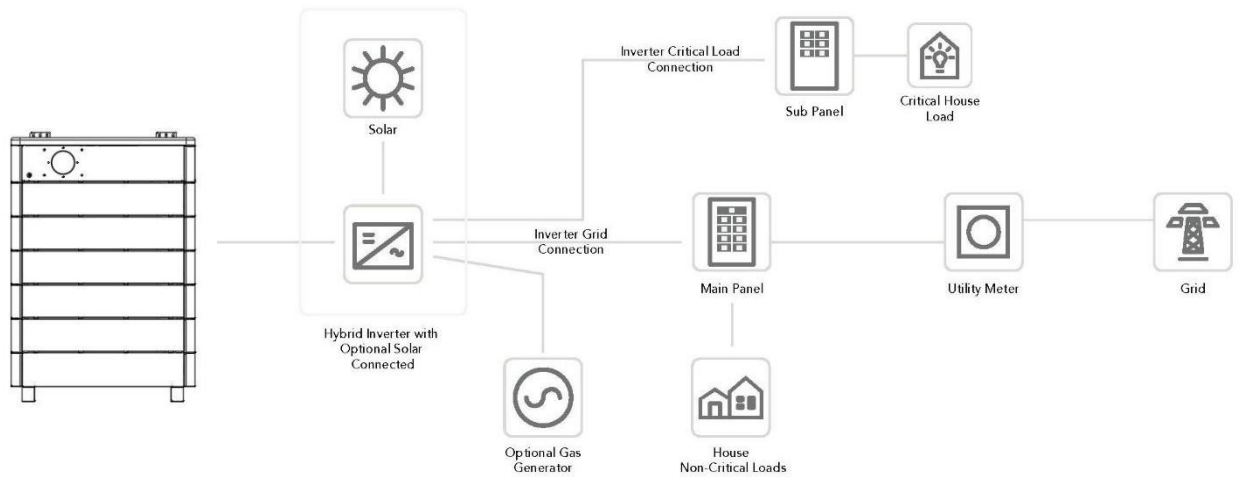

Figure 4.1. Schematic diagram of solution

4.2. Be Familiar with system

Be careful when unpacking the system. The whole system is heavy. Don't lift it with a pole. There are sliding wheels under the system to move. The weight of the battery can be found in the chapter "specifications".

Familiar with batteries. The battery poles are located on the right side of the battery. The battery polarity is shown on the left side of the battery. The positive pole is represented by "+" and the negative pole by "-".

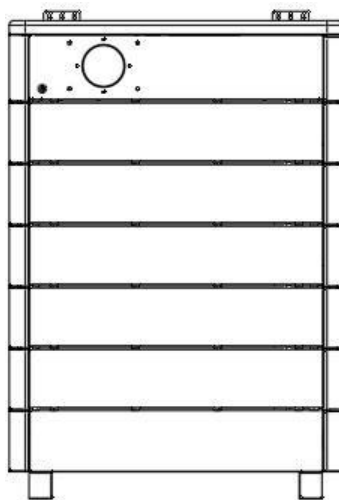

Figure 4.2.1. Side view of the whole system

4.3. Precautions before Installation

Before installation, be sure to read the contents in Chapter 1 Safety Precautions, which is related to the operation Safety of installation personnel, please pay attention to.

4.4. Safety Gear

It is recommended to wear the following safety gear when dealing with the battery pack:



Insulated gloves



Safety goggles



Safety shoes

4.5. Tools

The following tools are required to install the battery pack:



Wire cutter



Cable clamp



Screwdriver



M12*120 Embedded Expansion Bolts*4



M6*80 Embedded Expansion Bolts*6

NOTE:

- *Use properly insulated tools to prevent accidental electric shock or short circuits. If insulated tools are not available, cover the entire exposed metal surfaces of the available tools, except their tips, with electrical tape.*

5. Installation











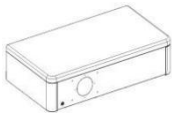

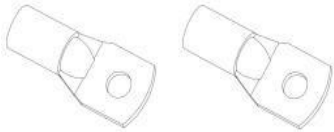
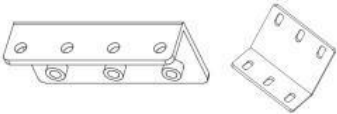

5.1. Package Items

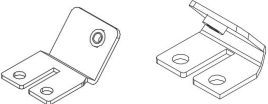

Unpacking and check the Packing List:

1) Packing List:



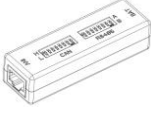

After receiving the complete system, please check to ensure that all the following components are not lost or damaged Broken.

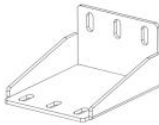
The required form of components for master and base installation is given below.

 <p>Main Controller case×1</p>	 <p>Base</p>	 <p>Battery terminal × 2</p>
 <p>Controller fixing bracket×2</p>	 <p>M8*18x2</p>	 <p>M5*16x6</p>
 <p>M4*10x8</p>	 <p>M3*12x3</p>	 <p>User's manualx1</p>
 <p>Positive and negative terminals×1</p>	 <p>Registered jack × 2</p>	 <p>RJ45 wire for paralleling × 1</p>
 <p>RJ45 wire for Sol-Ark inverter × 1</p>	 <p>Antenna × 1</p>	 <p>Cable × 1</p>

 <p>Pin order select box (optional) × 1</p>	 <p>Internal 6-angle wrench × 1</p>	 <p>Limit bracket × 2</p>
--	--	--

The required form of components for battery module installation is given below.

 <p>Battery case</p>	 <p>Fixed frame</p>
 <p>M3*12 × 3</p>	 <p>M4*10 × 4</p>

The form below indicates the screwdriver and torsion for corresponding screw:

Screw type	Screwdriver	Torsion
M3×12	5mm cross screwdriver	0.55±0.055 N.m
M4×10	5mm cross screwdriver	1.20±0.12 N.m
M5×16	5mm cross screwdriver	2.80±0.28 N.m
M8×18	M8 sleeve	12±1.2 N.m

2) Connector

Each system will be equipped with a positive connector and a negative connector. The two connectors are not connected to the cable, and users can wire according to the actual application needs.



Positive connector

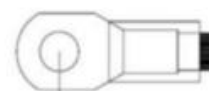

Negative connector

Inverter Power	Quantity of Battery Modules	Cable specification	
		AWG	mm ²
5kW	1	4	25
9kw	2	1/0	50
12kw-14kw	3	3/0	70
15kw	4-8	4/0	95

NOTE:

● Safety and compliance with regulations require the installation of independent DC overload protector or disconnecting device between battery and inverter. Even if disconnecting devices are not required in some applications, overload protection is still required. Refer to the table below for typical amperes as the required fuse or circuit breaker standard. Ring terminal

Warning! All wiring must be performed by professionals.  warning! It is very important to connect the battery with proper cable for the safe and efficient operation of the system. To reduce the risk, use the correct cable and terminal sizes recommended below.

3) Each system will be equipped with a positive terminal and a negative terminal. The two connectors are not connected with cables, so users can connect wires according to actual application needs.

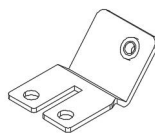

Positive connector

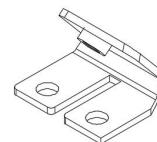

Negative connector

4) Communication connecting line between system and inverter (Optional)

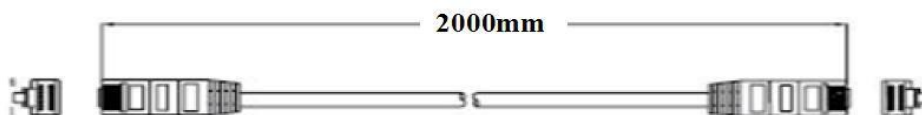

5) Pin order select box (optional)



Set the pin order of the communication cable of battery and inverter, cooperate with 2 standard network cable.

5.2. Installation Location

Make sure that the installation location meets the following conditions:

- ◆ The area should be avoided with touching water.
- ◆ The -P version is required if it will be installed in the place close to the sea.
- ◆ The floor is flat and level.
- ◆ There are no flammable or explosive materials.
- ◆ The ambient temperature is within the range from 0° C to 50° C.
- ◆ The temperature and humidity are maintained at a constant level.
- ◆ There is minimal dust and dirt in the area.
- ◆ The distance from heat source is more than 2 meters.
- ◆ The distance from air outlet of inverter is more than 0.5 meters.
- ◆ Do not install outside directly.
- ◆ Do not cover or wrap the battery case or cabinet.
- ◆ Do not place at a child or pet touchable area.
- ◆ The installation area shall avoid of direct sunlight.
- ◆ There are no mandatory ventilation requirements for battery module, but please avoid of installation in confined area. The aeration shall avoid of high salinity, humidity, or temperature.
- ◆ For household installation, only single row unit installation is allowed, and the installation capacity is limited to 40KWH.
- ◆ Non-household application scenarios can be installed in multiple rows units, with each row installed at a spacing of 1.5 meters and above.



CAUTION

If the ambient temperature is outside the operating range, the battery pack stops operating to protect itself. The optimal temperature range for the battery pack to operate is 0° C to 55° C. Frequent exposure to harsh temperatures may deteriorate the performance and life of the battery pack.

5.3. Installation

A. Stack the whole cluster

- 1) According to the current number of modules, make sure the corresponding dimensions. The figure below indicates specific dimensions.

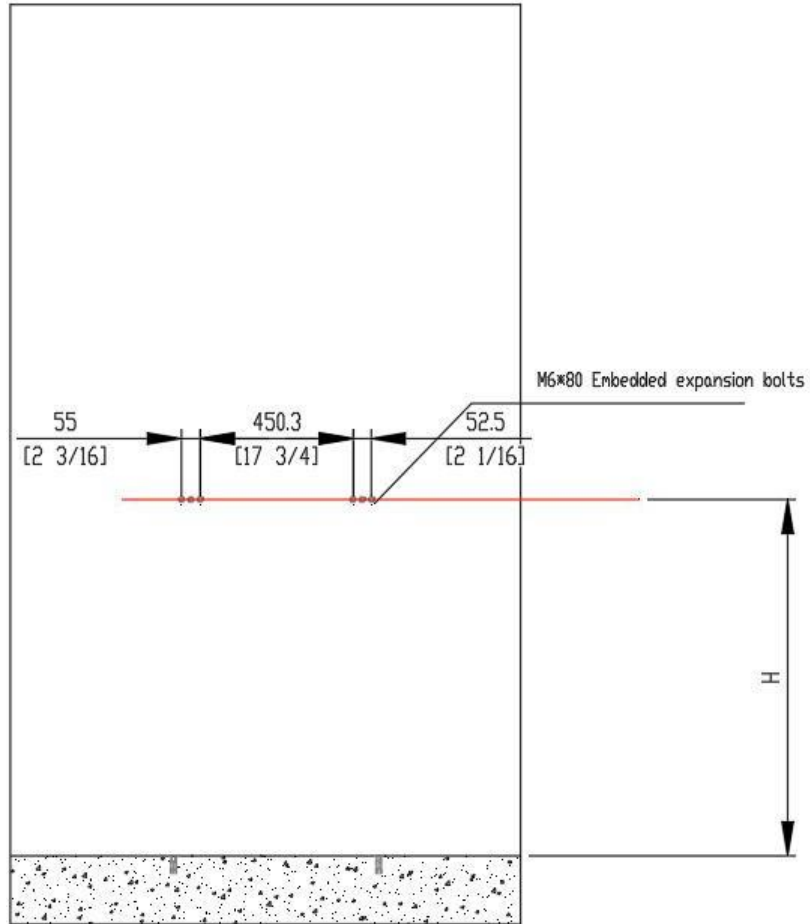

Number of Modules	Height in inch (± 0.197 inch)	Height (± 5 mm)
2	30.5	775.5
3	35.9	911.0
4	41.2	1046.5
5	46.5	1182
6	51.9	1317.5
7	57.2	1453
8	62.5	1588.5

2) Pre-embed the expansion bolts based on the dimensions as the graph below showed.

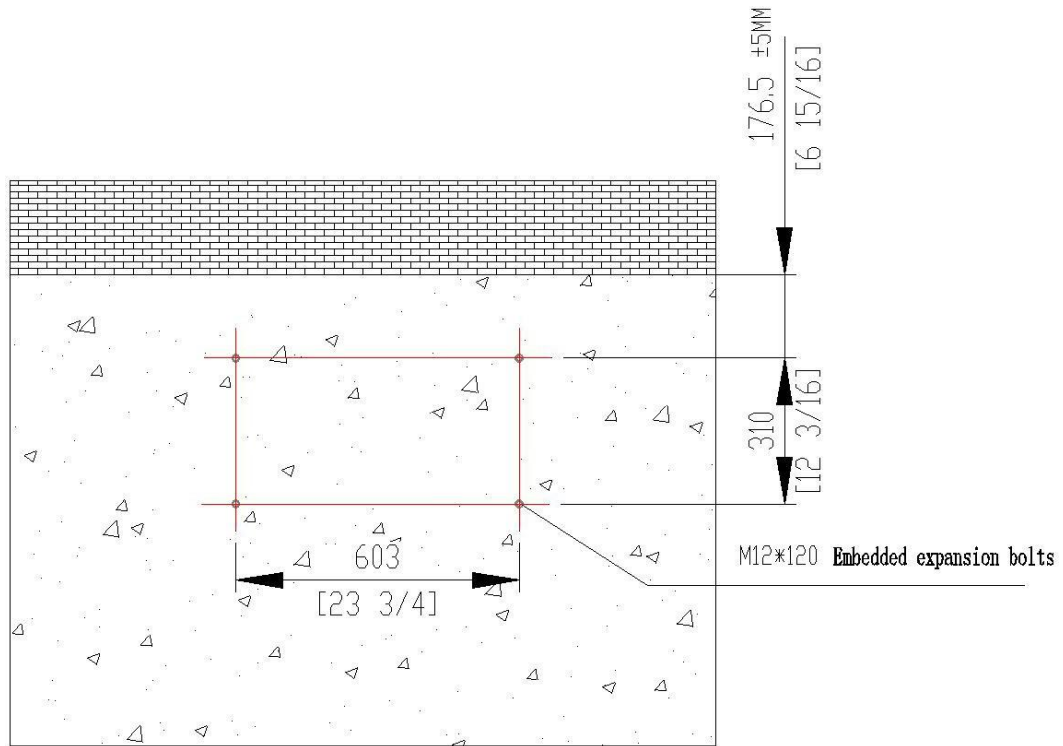

- 3) Set down the base, make sure that the base is 120mm away from the wall first, and then lock the screws.

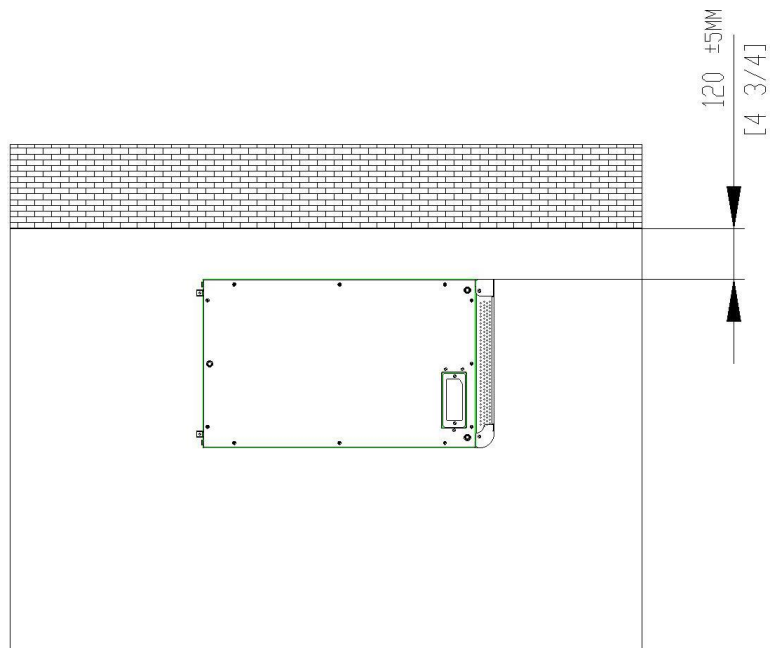

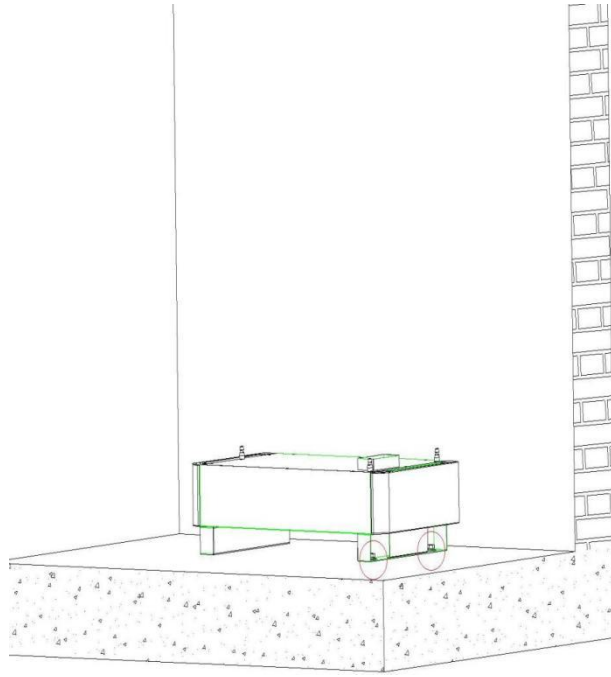

4) Align and stack the required modules and cover the controller finally.

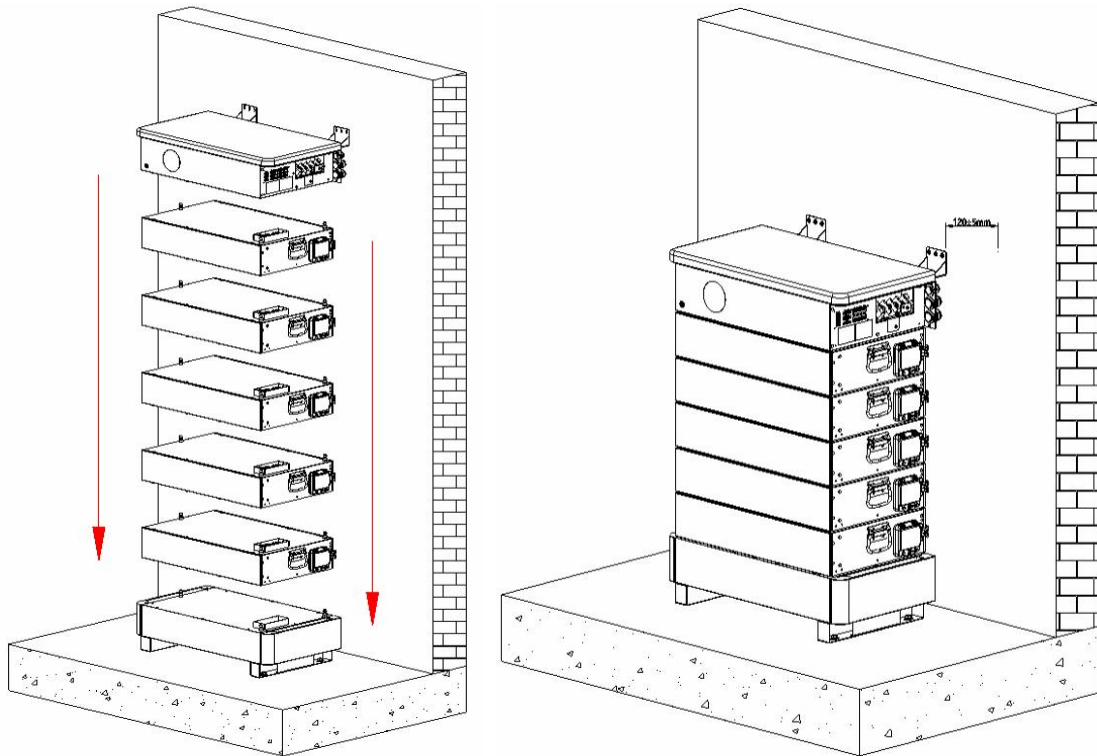

Note: Due to the side panels are already fixed on master and slaves, users need to dismantle those firstly.

5) Assemble and lock the controller fixing bracket according to the position of holes on the wall as the graph below shows. After this step, check whether the cluster is $120\pm 5\text{mm}$ away

from the wall and whether the height of cluster can match the holes on the wall one more time.

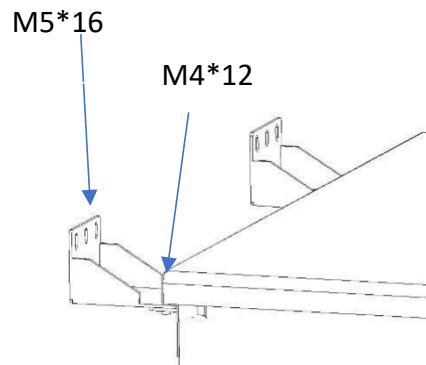

6) Lock the fixed strip on the side and lock the fixed strip with battery modules.

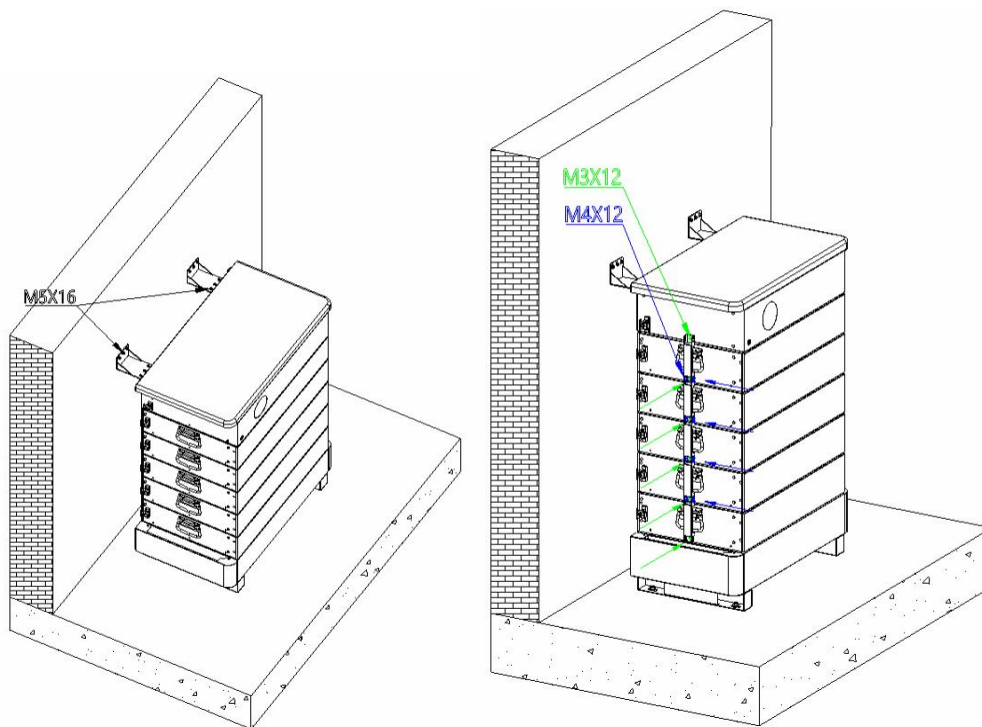

7) As for grounding, user needs to connect the grounding wire to the controller fixed bracket which be indicated as the graph shows below.

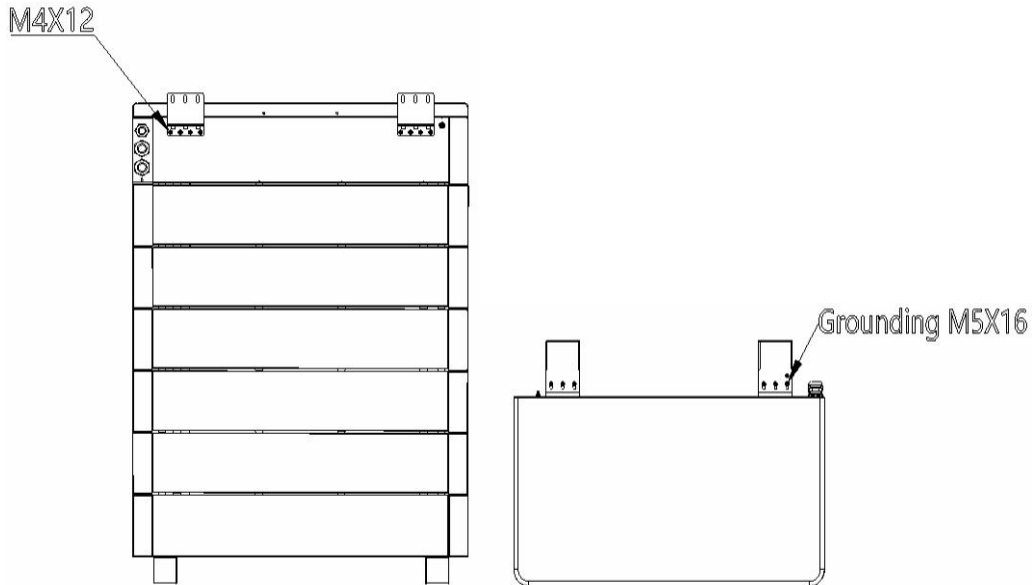

8) Turn on the battery's power and controller's power and wait for the screen to return to normal (soc and soh are not 0, and all the battery icons are solid, no blinking and error message, etc.). Turn the dial address to 63 which users can find in section 3.4 on main controller to automatically identify the inverter and set the protocol after it is turned on. Confirm that the stacking is successful and turn off the main control power and the breaker of PDB.

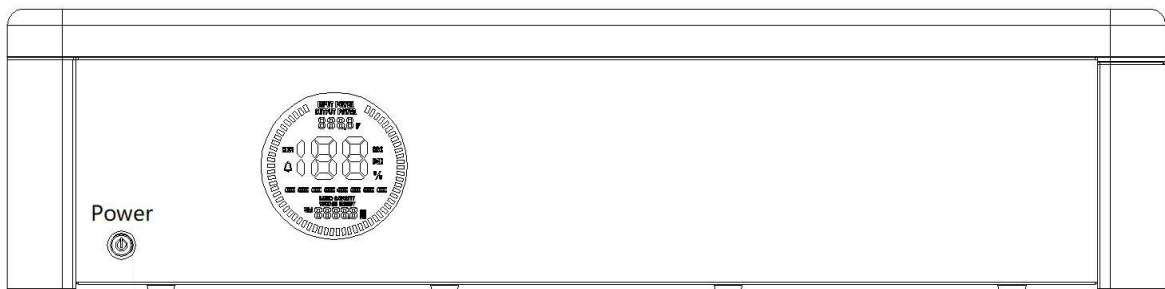

NOTE:

- Do not turn off the power of slave modules.
- Before starting the system, the operator should strictly check the connection terminal to ensure that the terminal is firmly connected, check whether the battery address is set correctly, and whether the inverter switches are in the off state. Do a good job in safety protection and turn on the inverter in the following order; when installing the system, the battery module bottom insulation skin remove the lower connector of the battery module is covered by a PC piece, which should be torn off before installation.

9) Make sure that the controller power is off, connect the battery to the inverter, pay attention to the distinction between positive and negative electrodes and the connection of the communication cable, and connect the WIFI antenna. After confirming that the connection is correct, communicate with the inverter and check whether the functions of charging and discharging is normal. The details of connection can be found in chapter 3.

10) After confirming that all the steps mentioned above are correct, secure the side cover with screws.

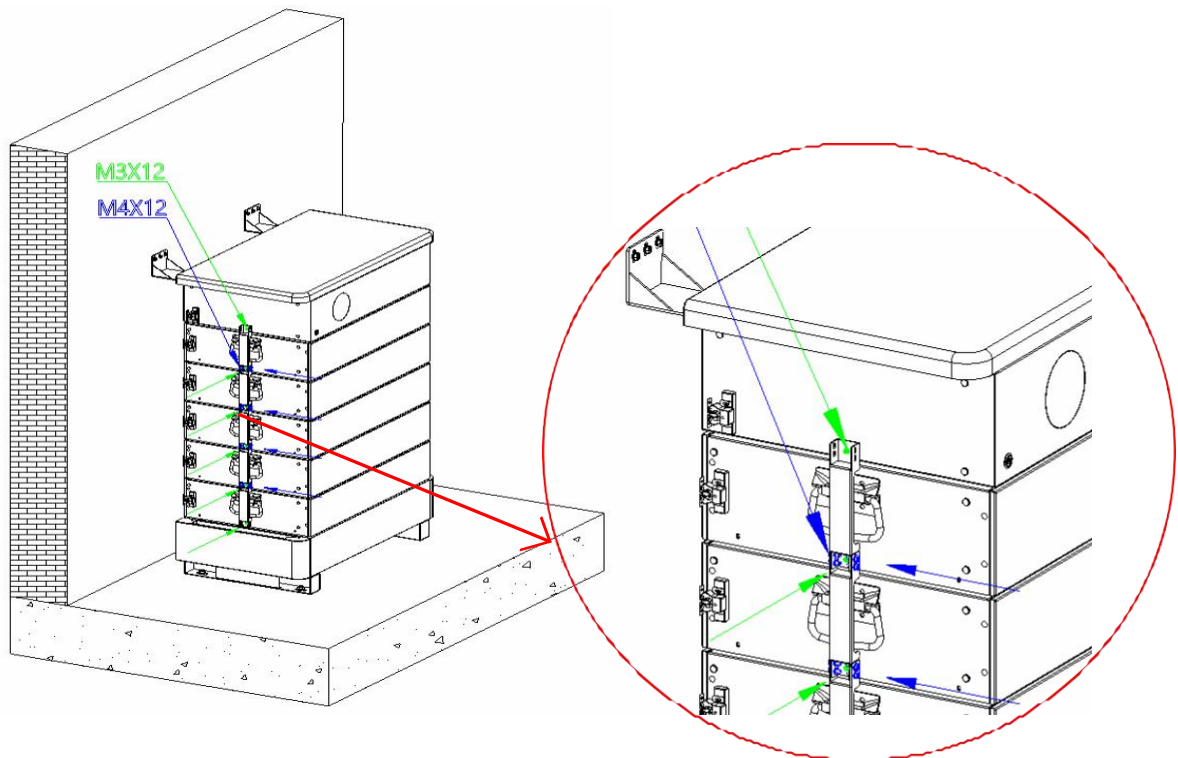
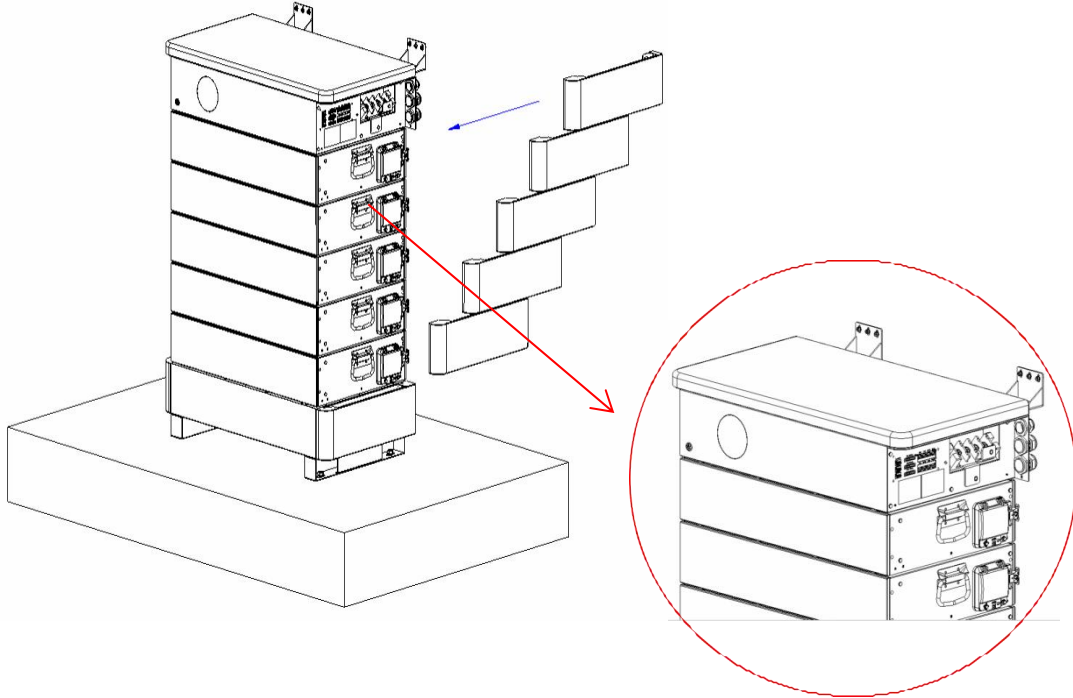

5.4. Parallel connection(Optional)

- 1) Check all connection terminals and communication lines carefully.
- 2) The master control address shall be set to "1" for communication between the master control and the inverter (a host system can be configured with up to 15 slave systems). Turn off the Controller switch before connecting the inverter.

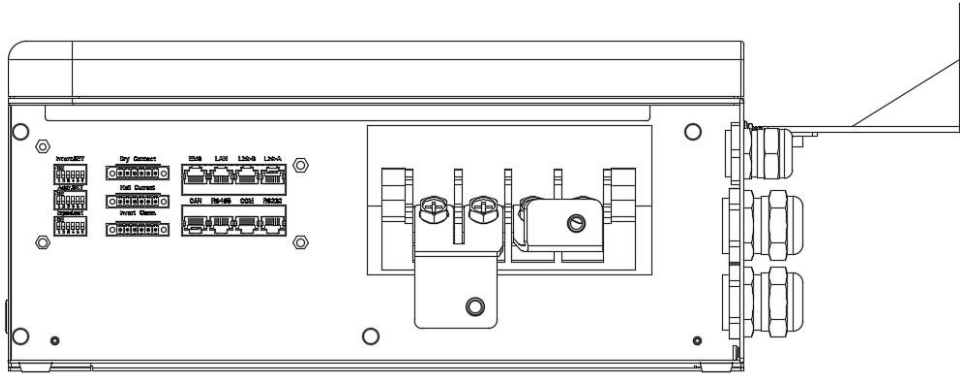

- 3) Connect the parallel port of the slave to the communication cable of the host, connect the positive pole of the slave to the positive pole of the host, connect the negative pole of the slave to the negative pole of the host, connect the parallel cable of the slave to the host, and finally connect the communication cable of the host to the frequency converter

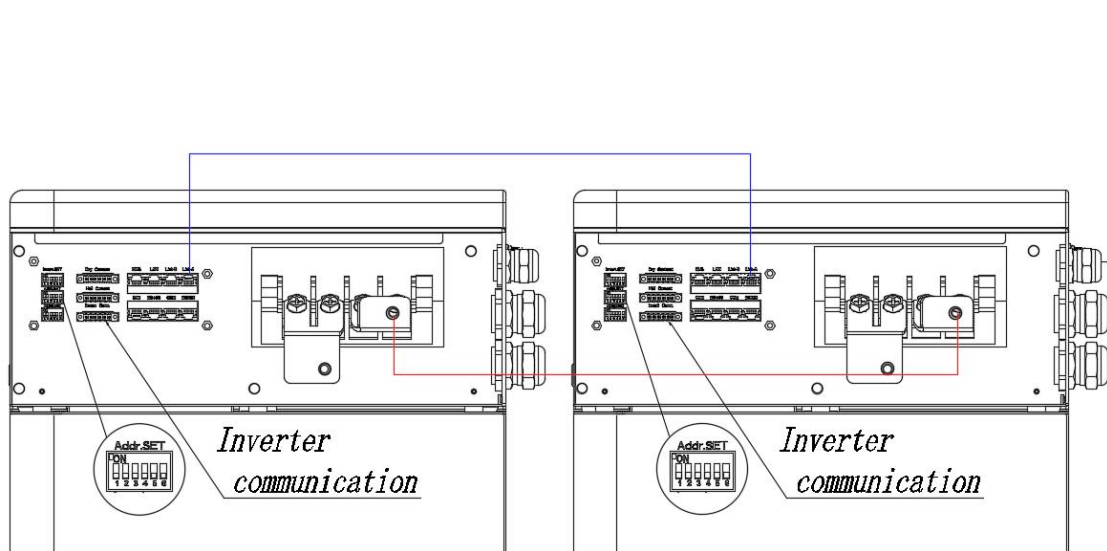

- 4) Limit the distance between the two units to be no less than 300mm, and the recommended distance is 500mm.

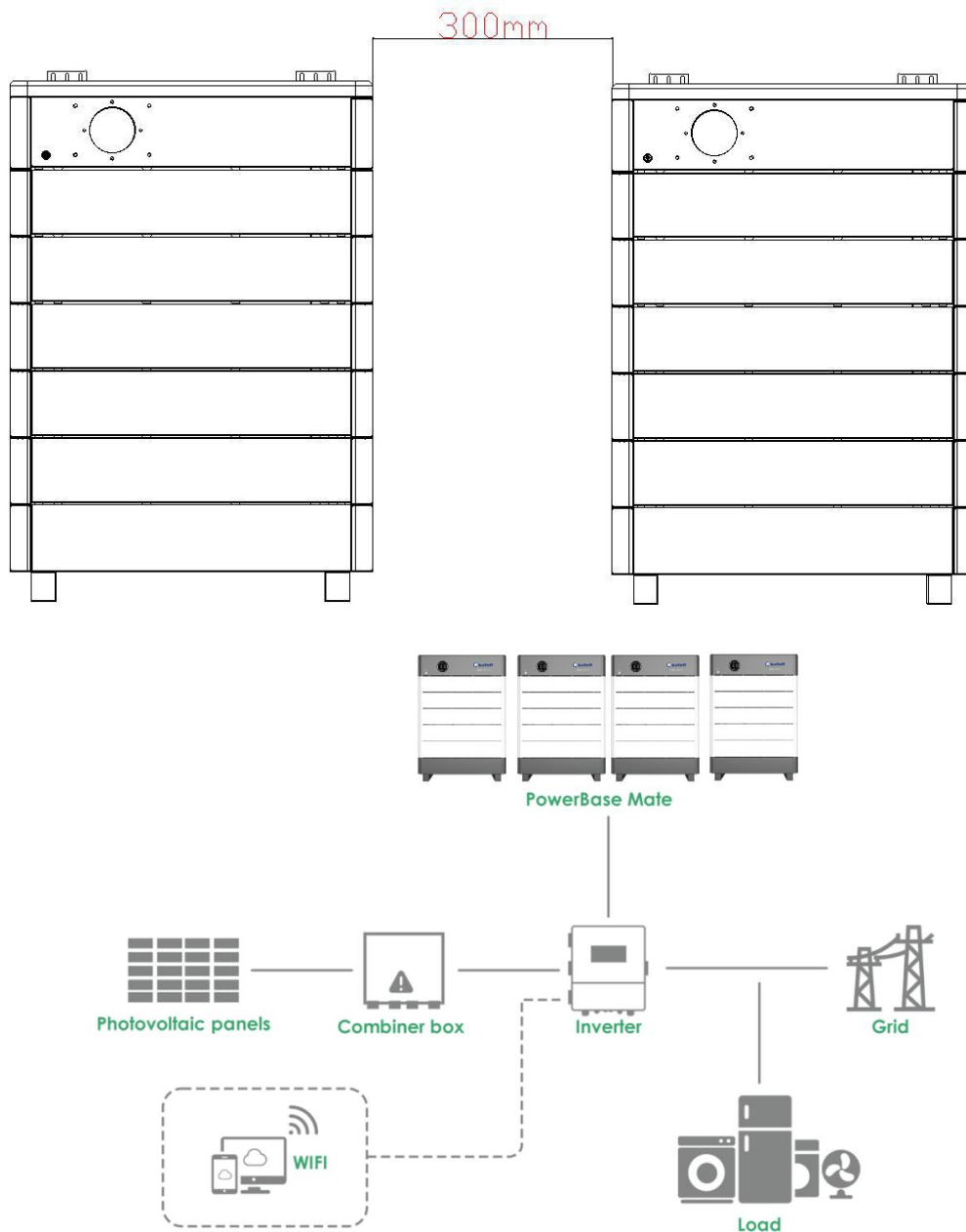

Figure 5.4. Schematic diagram of parallel solution



Note: after installation, please do not forget to contact the supplier to register online for full warranty

NOTE:

- In order to avoid current pulse during start-up, the predischarge function should be added to high voltage system. All connected batteries should be turned on first, and then the circuit breaker between high voltage system and inverter should be turned on.
- Circuit breaker shall be installed between high voltage system and inverter to protect system safety. All installation and operation must comply with local electrical standards.

6. Trouble Shooting Steps

6.1. Problem Determination Based on

- 1) Whether the system can be opened.
- 2) If the system is turned on, check whether the display is on
- 3) If the display goes off, check whether the system can be charged/discharged.

6.2. Preliminary Determination Steps

1) The system cannot be turned on and the system display is not illuminated. If the external switch of the system is turned on and the external power supply voltage exceeds 48V, the system still cannot be started and operated, please contact the dealer.

2) The system can be turned on, but the display shows a fault and cannot be charged or discharged. If the red light is on, it indicates that the system is abnormal. Please check the following values:

a. Temperature: Above 50°C or under -20°C, the system could not work in.

Discharging Above 50°C or under 0°C, the system could not work in charging.

b. Current: If current is greater than 300A, battery protection will turn on.

Solution: Check whether current is too large or not, if it is, to change the settings on power Supply side.

c. High Voltage: If charging voltage above 55.5V, battery protection will turn on.

Solution: Check whether voltage is too high or not, if it is, to change the settings on power supply side.

d. Low Voltage: When the battery discharges to 40.5V or less, battery protection will turn on.

Solution: Charge the battery for some time.

Excluding the four points above, if the faulty is still cannot be located, turn off battery and repair.

6.3. The Battery Cannot be Charged or Discharged

1) Cannot be charged:

Disconnect the power cables, measure voltage on power side, if the voltage is 53~54V restart the battery, connect the power cable and try again, if still not work, turn off battery and contact distributor.

2) Unable to discharge:

Disconnect the power cables and measure voltage on battery side, if it is under 44V please charge the battery; if voltage is above 48V and still cannot discharge, turn off battery and contact distributor.

P/N: 118.601.00.0003



Our Energy Works For You



Website



Linkedin

 www.zruipower.com

 support@zruipower.com

 +86(0755)2833 9703

ADD:Rm B0302, Building 1, Skyworth Maker World Science Park, No. 12, Gaoke Avenue, Baolong Street, Longgang District, Shenzhen